

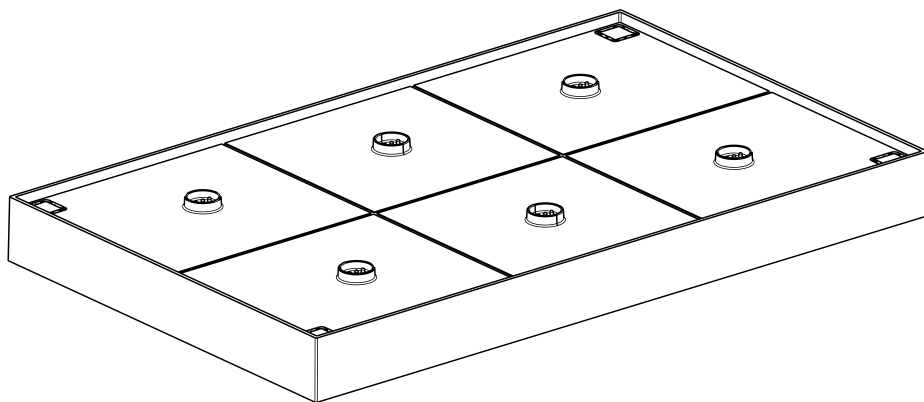

Multi-Contact Charging Shelf



Product Information

Multi-Contact Charging Shelf

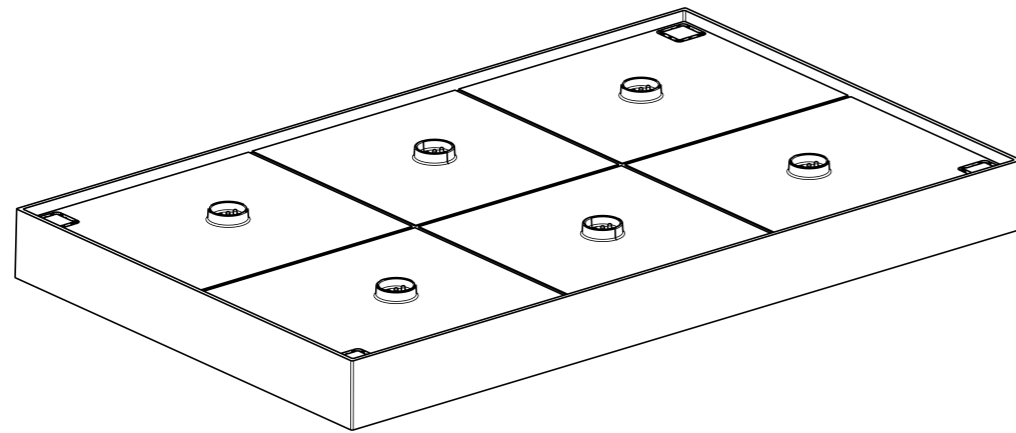

Product Description

Model H1100C	Application Multi-Contact Charging Shelf	Net Weight 2Kg	Inner Box 340 x 50 x 340mm	Outer Carton 360 x 320 x 550mm	Pcs/Ctn 6
Input Voltage AC100-240V	Power 45W	Safety Class CLASS II	Ingress Protection IP20		
Materials Reinforced plastic shelf with 6 electrical docks, extruded reinforced plastic profiles.					
Multi-Contact charging station (max. 6 lamps). Possible to use multiple sockets (max. 3 levels) for simultaneous multiple charging (up to 18 lamps). Suitable for professional use.					

AC-DC Adapter

Multi Contact Charging Shelf (6)

Stacking Posts

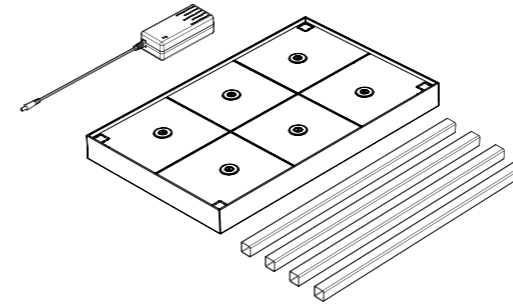

Use Power Adapter Cable Supplied

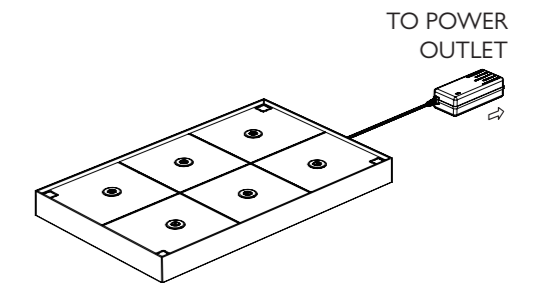

1

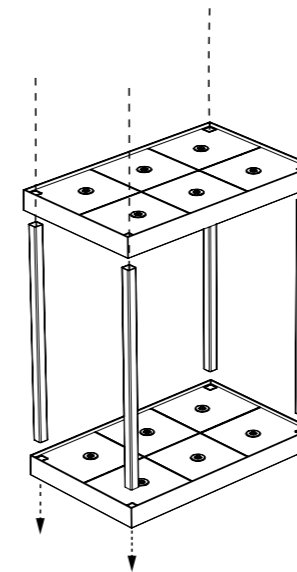

2

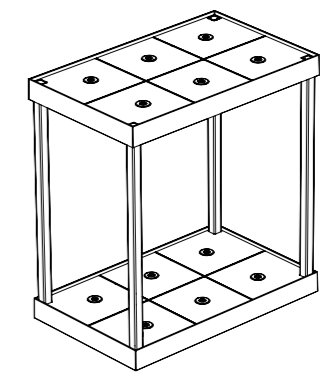

3

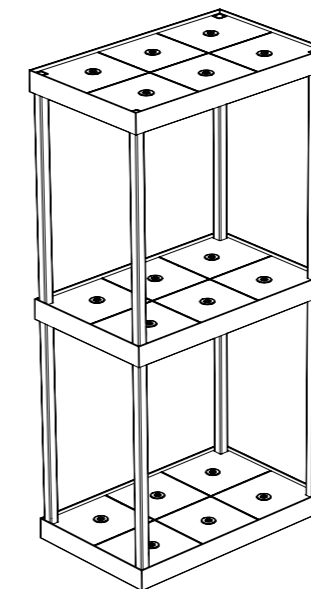

STACKABLE UP TO MAX 3 LEVELS

WHENEVER INSTALLING OR REARRANGING SHELVING, NEVER LIFT ASSEMBLED SHELVING.





utopia

Head Office & Showroom
Utopia Tableware
One Langham Park,
Mansfield Road,
Chesterfield, S41 0GG

T. 01246 858800
E. info@utopia-tableware.com

www.utopia-tableware.com
[/utopiatableware](#)
[@utopiatableware](#)

